

# CHIOCCIOLA

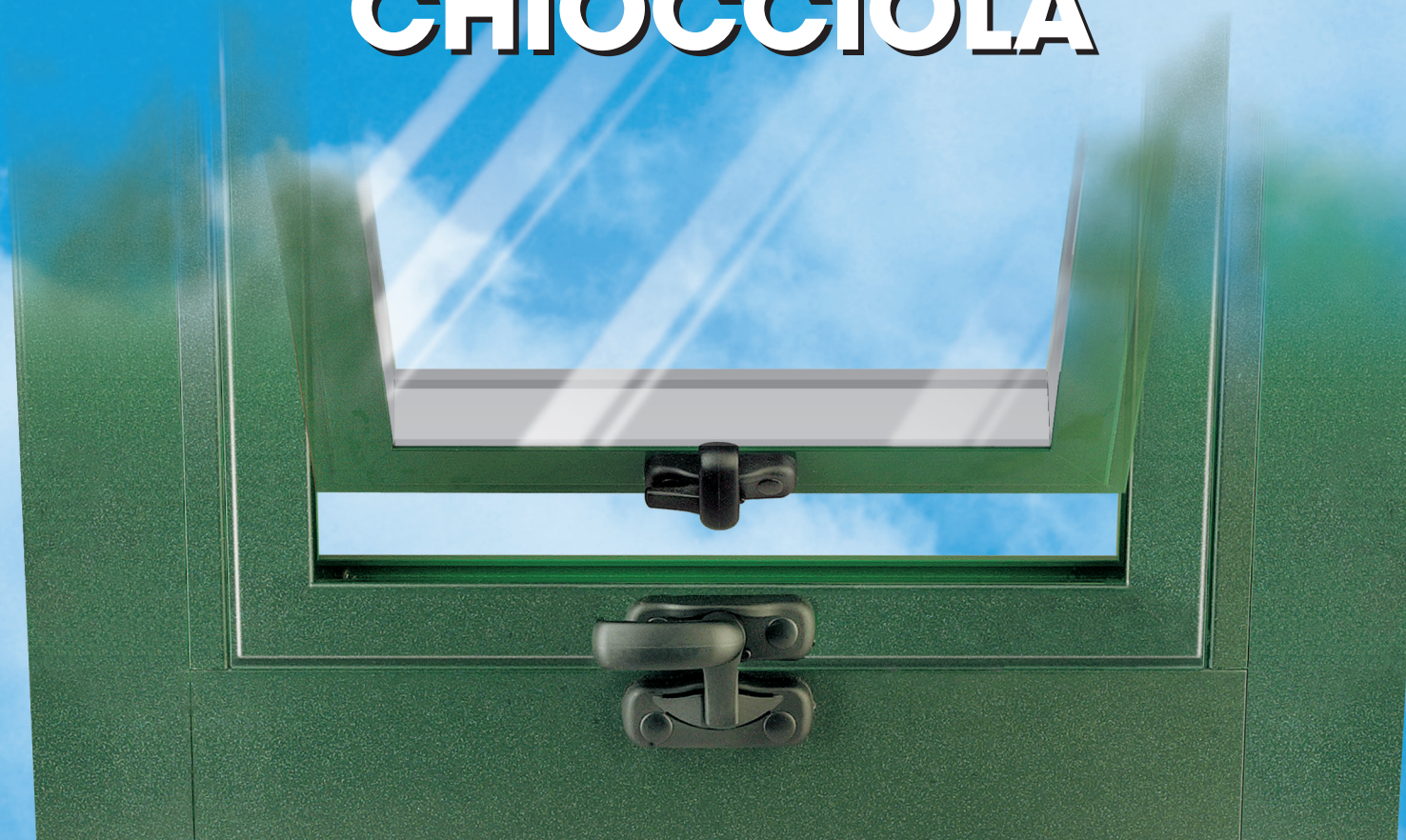

AZIENDA CON SISTEMA QUALITÀ  
CERTIFICATO DA DNV  
=UNI EN ISO 9001/2000=

AZIENDA CON SISTEMA AMBIENTALE  
CERTIFICATO DA RINA  
UNI EN ISO 14001/2004



# CHIOCCIOLA

Chiudi anta a tirare e spingere con spessori da mm 2,5 viti inox e tappi copriforo

## A TIRARE

cod. 099992174



## A SPINGERE

cod. 099992174

+  
cod. 099992183

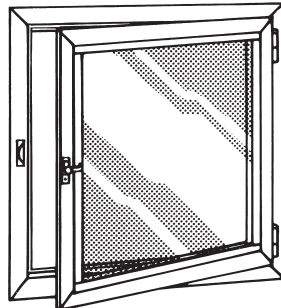

## SPESSORE mm 2

cod. 099992189

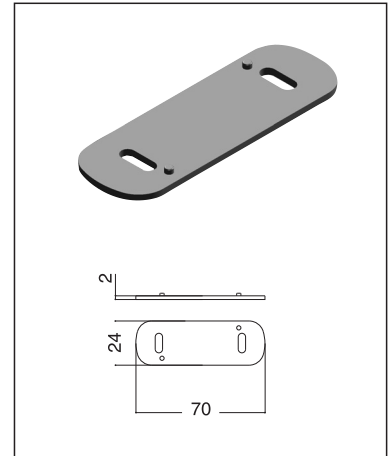

## SPESSORE mm 3

cod. 099992190

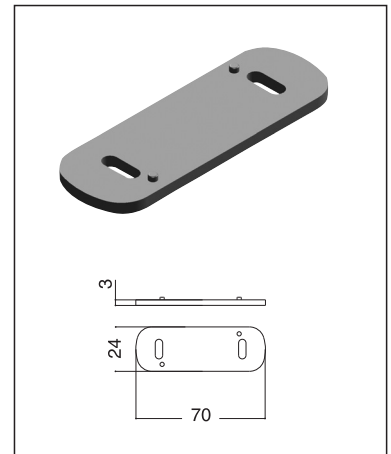

Gli spessori da mm 2 e mm 3  
**NON SONO INCLUSI IN CONFEZIONE**

cod. 099992174

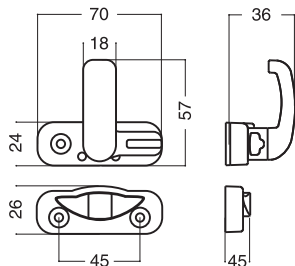

cod. 099992183

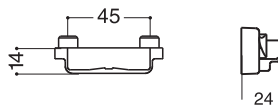

## INVERSIONE DELLA MANIGLIA

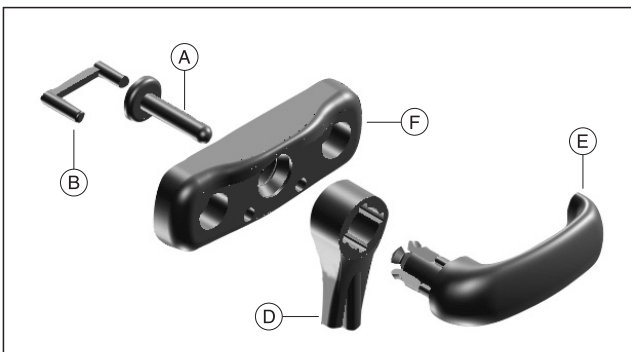

**1** Estrarre il perno **A**, la forcella **B** e gli elementi **E+D** dal nucleo **F**. Sfilare la leva **E** dall'elemento **D**.

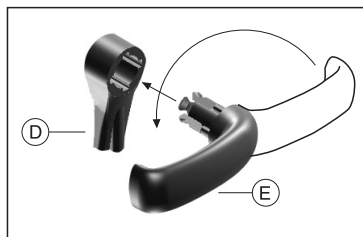

**2** Ruotare di 180° la leva **E** da dx verso sx e assemblare con pressione i due elementi.

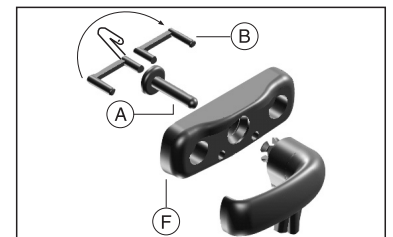

**3** Inserire con pressione gli elementi **D** ed **E** già assemblati nel nucleo **F**. Inserire il perno di bloccaggio **A** e in ultimo la forcella di battuta **B** dopo averla ruotata.

La ESINPLAST Srl si riserva il diritto di apportare variazioni dimensionali senza obbligo di preavviso.



**ESIN** *plast* s.r.l.

PROGETTAZIONE E REALIZZAZIONE ARTICOLI TERMOPLASTICI  
REALIZZAZIONE STAMPI

60030 MONSANO/AN - ITALY - Via S. Ubaldo, 31/D - Tel. +39 0731 61582 r.a. - Fax +39 0731 615830-40

www.esinplast.it - e-mail: esinplast@esinplast.it